

Vacuum Switch

VSA200, VSD200

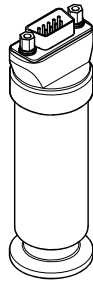

Operating Manual
Incl. EU Declaration of Conformity
tina65e1-b (2016-10)

Product Identification

In all communications with INFICON, please specify the information on the product nameplate. For convenient reference copy that information into the space provided below.

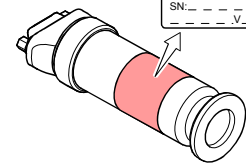
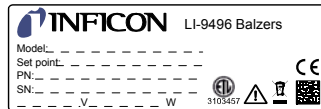

Validity

This document applies to products with the following part numbers:

VSA200

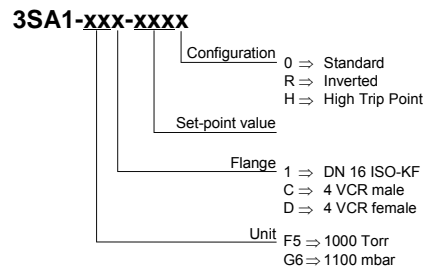

VSD200

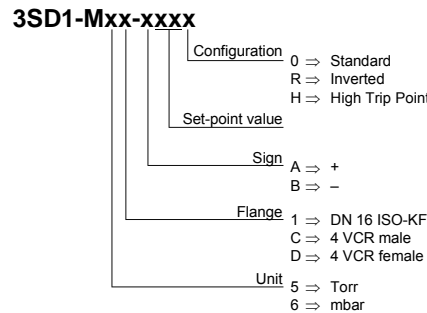

The part number (PN) can be taken from the product nameplate.

If not indicated otherwise in the legends, the illustrations in this document correspond to the vacuum switch with vacuum connection DN 16 ISO-KF. They apply to vacuum switches with other vacuum connection by analogy.

We reserve the right to make technical changes without prior notice.

All dimensions in mm.

Intended Use

The vacuum switches have been designed for the use in vacuum systems as absolute pressure switch (VSA200) or as differential pressure switch (VSD200) in different measurement ranges.

Trademark

VCR® Swagelok Marketing Co.

Safety

Symbols Used

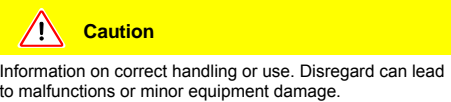
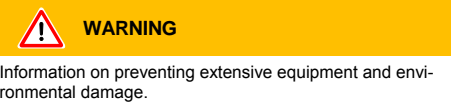
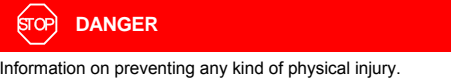

Personnel Qualifications

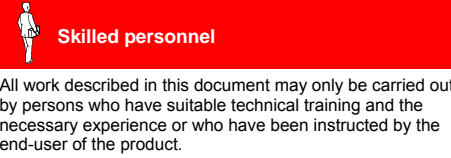

General Safety Instructions

- Adhere to the applicable regulations and take the necessary precautions for the process media used. Consider possible reactions between the materials and the process media.
- Adhere to the applicable regulations and take the necessary precautions for all work you are going to do and consider the safety instructions in this document.
- Before beginning to work, find out whether any vacuum components are contaminated. Adhere to the relevant regulations and take the necessary precautions when handling contaminated parts.

Communicate the safety instructions to all other users.

Liability and Warranty

INFICON assumes no liability and the warranty becomes null and void if the end-user or third parties

- disregard the information in this document
- use the product in a non-conforming manner
- make any kind of interventions (modifications, alterations etc.) on the product
- use the product with accessories not listed in the product documentation.

The end-user assumes the responsibility in conjunction with the process media used.

Gauge failures due to contamination or wear and tear, are not covered by the warranty.

Technical Data

Measurement range	VSA200 (absolute)	1100 mbar (F.S.) 1000 Torr (F.S.)
	VSD200 (relative to atm)	-100 ... +50 mbar, Torr
Setpoint (setting range)	VSA200	30 ... 1060 mbar 20 ... 970 Torr
	VSD200	-99 ... +46 mbar, Torr
Switching contact		changeover contact, floating
Hysteresis		2 % F.S. above setpoint
Contact rating		≤30 V (dc) / 1 A (dc) ≤30 V (ac) / 0.3 A (ac)
Switching characteristics ¹⁾		Low Trip Point
Accuracy		≤0.5 % F.S.
Resolution		10 bit
Switching frequency		0.5 Hz
Response time		≤45 ms

Temperature effect on zero and span		±0.02 % F.S. / 1K
Long-term stability		±0.5 % F.S. / a
Effect supply voltage		±0.005 % F.S. / V
Starting time		1 s
Service life		>1×10 ⁸ cycles
Electronic Relay		25'000 h >3×10 ⁶ cycles

Supply

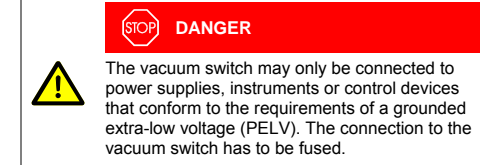

Supply voltage		+14 ... +30 V (dc)
Current consumption		≤15 mA
Power consumption		≤0.5 W

Electrical connection		D-Sub, 9 pin, male
Cable		6 pin plus shielding
Cable length		≤100 m (8×0.14 mm ²)

Materials exposed to vacuum		
Housing		1.4571, 1.4404
Diaphragm		1.4435

Internal volume		
DN 16 ISO-KF		2.81 cm ³
4 VCR®		0.93 cm ³
Admissible pressure (abs.)		
VSA200		5 bar
VSD200		2 bar

Admissible temperatures		
Operation		0 ... +70 °C
Storage		-40 ... +80

Relative humidity		≤80 at temperatures up to ≤+31 °C, decreasing to 50 at +40 °C
-------------------	--	---

Use		indoors only, altitude up to 4000 m NN
Mounting orientation		any
Degree of protection		IP40

Dimensions [mm]

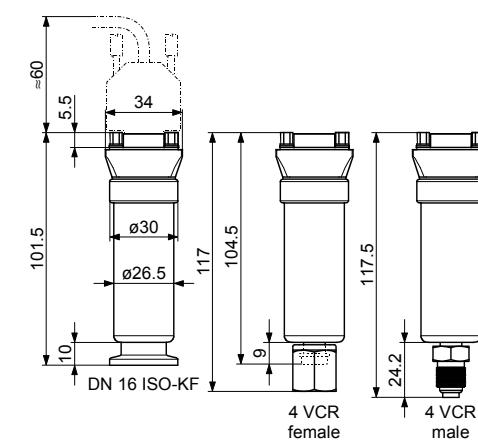

Weight =140 g

Installation

Vacuum Connection

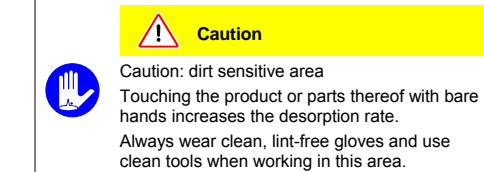
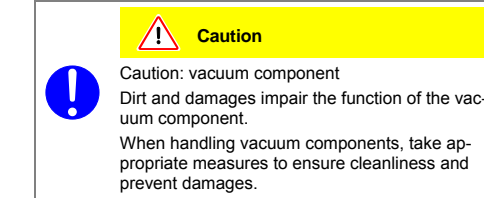
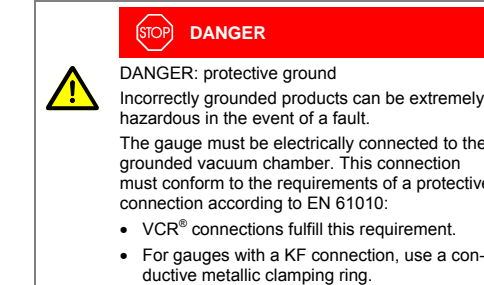
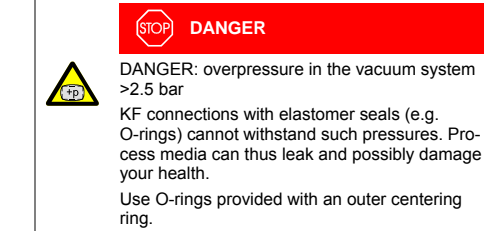
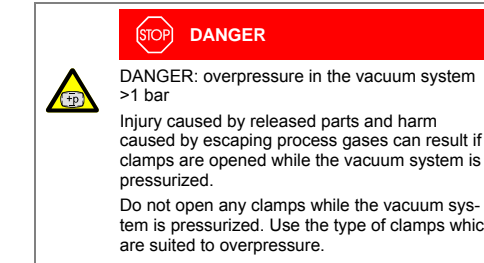

Remove the protective lid and install the product to the vacuum system.

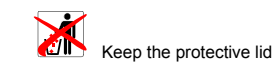
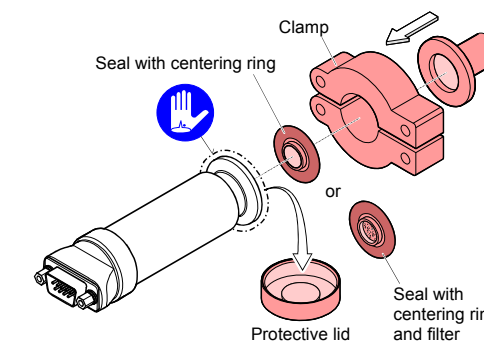

Power Connection

Make sure the vacuum connection is properly made (→ "Vacuum Connection").

Before connecting or disconnecting the product, turn off the control system.

If no sensor cable is available, make one according to the following diagram.

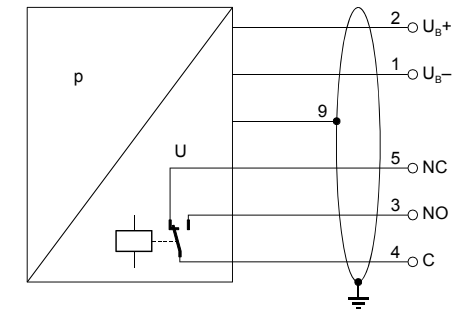

Pin 1 Supply common, GND
Pin 2 Supply +14V ... 30 V
Pin 3 Relay n.o.
Pin 4 Relay common
Pin 5 Relay n.c.
Pin 6 Internal common RxD
Pin 7 Internal common TxD
Pin 8 Internal common (com)
Pin 9 Housing (Chassis Ground)

Connect the cable to the vacuum switch.

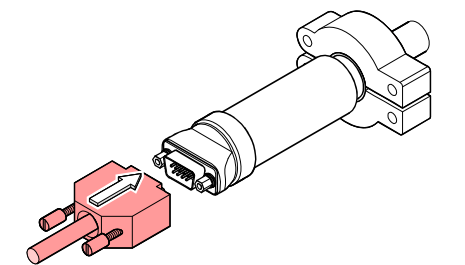

¹⁾ The switching characteristics and the setpoint can be programmed via the serial interface (pin 6, 7, 8).

Operation

The product is ready for operation as soon as it has been installed.

The gauge is factory calibrated while "standing upright". Due to changing the mounting orientation, a low zero drift could occur (0.05 % F.S.).

Setpoint, Switching Characteristics

The setpoint can be read and set to any pressure within the setting range of the vacuum switch with the communication software (→ [1]).

The switching characteristics of the setpoint can be programmed with the communication software (→ [1]).

Low Trip Point (default)

If the pressure in the vacuum system is lower than the setpoint, the relay is closed.

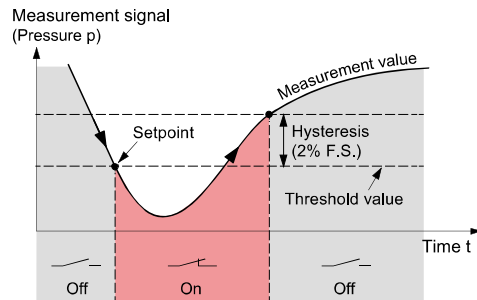

Deinstallation

DANGER

DANGER: contaminated parts
Contaminated parts can be detrimental to health and environment.
Before beginning to work, find out whether any parts are contaminated. Adhere to the relevant regulations and take the necessary precautions when handling contaminated parts.

Caution

Caution: vacuum component
Dirt and damages impair the function of the vacuum component.
When handling vacuum components, take appropriate measures to ensure cleanliness and prevent damages.

Caution

Caution: dirt sensitive area
Touching the product or parts thereof with bare hands increases the desorption rate.
Always wear clean, lint-free gloves and use clean tools when working in this area.

1 Vent the vacuum system.

2 Put the vacuum switch out of operation.

3 Unplug the sensor cable.

Before connecting or disconnecting the product, turn off the control system.

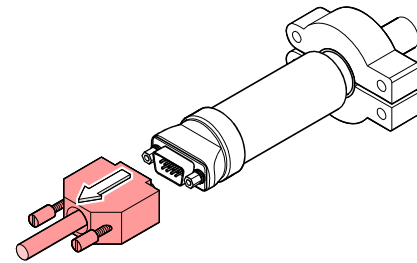

4 Remove the vacuum switch from the vacuum system and install the protective lid.

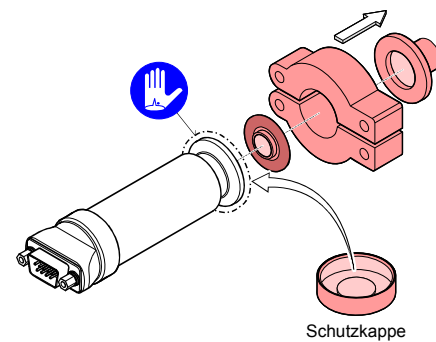

Maintenance, Repair

Under clean operating conditions, the product requires no maintenance.

The product is factory calibrated while "standing upright". Due to long time operation, contamination, or operation in other mounting orientation a zero adjustment may become necessary.

We recommend returning the product to your local INFICON service center for service.

Vacuum switch failures due to contamination or wear and tear are not covered by the warranty.

INFICON assumes no liability and the warranty becomes null and void if any repair work is carried out by the end-user or third parties.

Returning the Product

WARNING

WARNING: forwarding contaminated products
Contaminated products (e.g. radioactive, toxic, caustic or microbiological hazard) can be detrimental to health and environment.
Products returned to INFICON should preferably be free of harmful substances. Adhere to the forwarding regulations of all involved countries and forwarding companies and enclose a duly completed declaration of contamination¹⁾.

¹⁾ Form under www.inficon.com

Products that are not clearly declared as "free of harmful substances" are decontaminated at the expense of the customer. Products not accompanied by a duly completed declaration of contamination are returned to the sender at his own expense.

Disposal

DANGER

DANGER: contaminated parts
Contaminated parts can be detrimental to health and environment.
Before beginning to work, find out whether any parts are contaminated. Adhere to the relevant regulations and take the necessary precautions when handling contaminated parts.

WARNING

WARNING: substances detrimental to the environment
Products or parts thereof (mechanical and electric components, operating fluids etc.) can be detrimental to the environment.
Dispose of such substances in accordance with the relevant local regulations.

Separating the components

After disassembling the product, separate its components according to the following criteria:

- Contaminated components
Contaminated components (radioactive, toxic, caustic, or biological hazard etc.) must be decontaminated in accordance with the relevant national regulations, separated according to their materials, and disposed of.
- Other components
Such components must be separated according to their materials and recycled.

Accessories

Communication adapter with USB connector (2 m)	Ordering number 303-336
--	----------------------------

Further Information

[1] www.inficon.com
Communication software VSA200, VSD200

ETL Certification



ETL LISTED

The products VSA200 and VSD200

- conform to the UL Standard UL 61010-1
- are certified to the CAN/CSA Standard C22.2 No. 61010-1-12

EU Declaration of Conformity



We, INFICON, hereby declare that the equipment mentioned below complies with the provisions of the Directive relating to electromagnetic compatibility 2014/30/EU and the Directive on the restriction of the use of certain hazardous substances in electrical and electronic equipment 2011/65/EU.

Products

Vacuum Switch

VSA200, VSD200

Standards

Harmonized and international/national standards and specifications:

- EN 61000-4-3:2006 (EMC: radiated, radio-frequency, electromagnetic field immunity test)
- EN 61010-1:2010 (Safety requirements for electrical equipment for measurement, control and laboratory use)

Manufacturer / Signatures

INFICON AG, Alte Landstraße 6, LI-9496 Balzers

5 February 2016

5 February 2016

B. Andreanu *Alex Nef*

Dr. Bernhard Andreanu
Director Product Evolution

Alex Nef
Product Manager



LI-9496 Balzers
Liechtenstein
Tel +423 / 388 3111
Fax +423 / 388 3700
reachus@inficon.com
www.inficon.com