

IE414 & IE514 Sensors

High-end Hot Ion Gauges - Passive

The IE414 and IE514 are high-end vacuum sensors based on hot cathode ionization effect. The IE414 is a Bayard-Alpert gauge while the IE514 is based on the extractor principle. These passive gauges are combined and controlled by the IM540 vacuum gauge controller. Thanks to the modulation of the cathode emission current, the measurement range of IE414 spans over 9 decades from 1×10^{-2} mbar down to 1×10^{-11} mbar. The extractor principle allows IE514 reaching a lower measurement limit of 2×10^{-12} mbar thanks to its intrinsic reduction of X-ray and ion desorption effects.

ADVANTAGES

- High accuracy, individually calibrated sensor
- Exchangeable cathode
- High temperature bake-out 400 °C

IE414

- Bayard-Alpert sensing principle
- Measurement range to 2×10^{-11} mbar (1.5×10^{-11} Torr)
- Protection shield welded in place

IE514

- Extractor sensing principle
- Reliable to 2×10^{-12} mbar (0.75×10^{-12} Torr)
- Significant reduction of X-ray and ion desorption effects

APPLICATIONS

- Scientific and R&D applications requiring precise vacuum measurement in the ultra-high vacuum range and high temperature bake-out

OPERATING UNITS

- Vacuum Gauge Controller IM540



IE414 & IE514 Sensors

ORDERING INFORMATION

Type	IE414	IE514
Sensor DN 40 CF	399-661	399-663
Replacement cathode	399-676	399-677

SPECIFICATIONS

Type	IE414	IE514
Measurement system	hot cathode ionization	
Electrode system configuration	Bayard-Alpert	Extractor system
Measurement range (N ₂)	2 × 10 ⁻¹¹ ... 1 × 10 ⁻² mbar	2 × 10 ⁻¹² ... 1 × 10 ⁻⁴ mbar
X-ray limit	<1 × 10 ⁻¹¹ mbar	<1 × 10 ⁻¹² mbar
Sensitivity (N ₂ , typical)	17 mbar ⁻¹	6.25 mbar ⁻¹
Admissible temperature		
Ambient, in operation	+20 ... +80 °C	
Max. flange temp. with heat resistant gauge head cable set	250 °C	
Max. bake-out temperature without plugs	400 °C	
Storage temperature	+20 ... +50 °C	
Relative humidity		
Annual average	≤65% (non-condensing)	
On 60 days	≤85% (non-condensing)	
Use	within indoor rooms only, altitude up to 2000 meters above sea level	
Standard operating characteristics with IM540 controller		
Cathode (filament)		
Heating current	1.5 A	1.5 A
Heating voltage	3 V	3.7 V
Potential	+80 V	+100 V
Emission current range	0.1 ... 10 mA	1.6 mA
Anode (grid) potential	220 V	220 V
Collector potential	0 V	0 V
Reflector potential	-	+205 V
Max. power when baking out	90 mA / 480 V	45 mA / 480 V
Flange connection	DN 40 CF	
Materials exposed to vacuum		
Lead-in pins	NiFe	NiFe
Insulator	Al ₂ O ₃ ceramic	Al ₂ O ₃ ceramic
Pin sealing plate	NiFe	NiFe
Flange	stainless steel	stainless steel
Cathode	iridium with yttrium oxide coating	iridium with yttrium oxide coating
Anode	molybdenum	stainless steel
Collector	tungsten	tungsten
Reflector	NiFe	NiFe

IE414 & IE514 Sensors

DIMENSIONS

[mm]

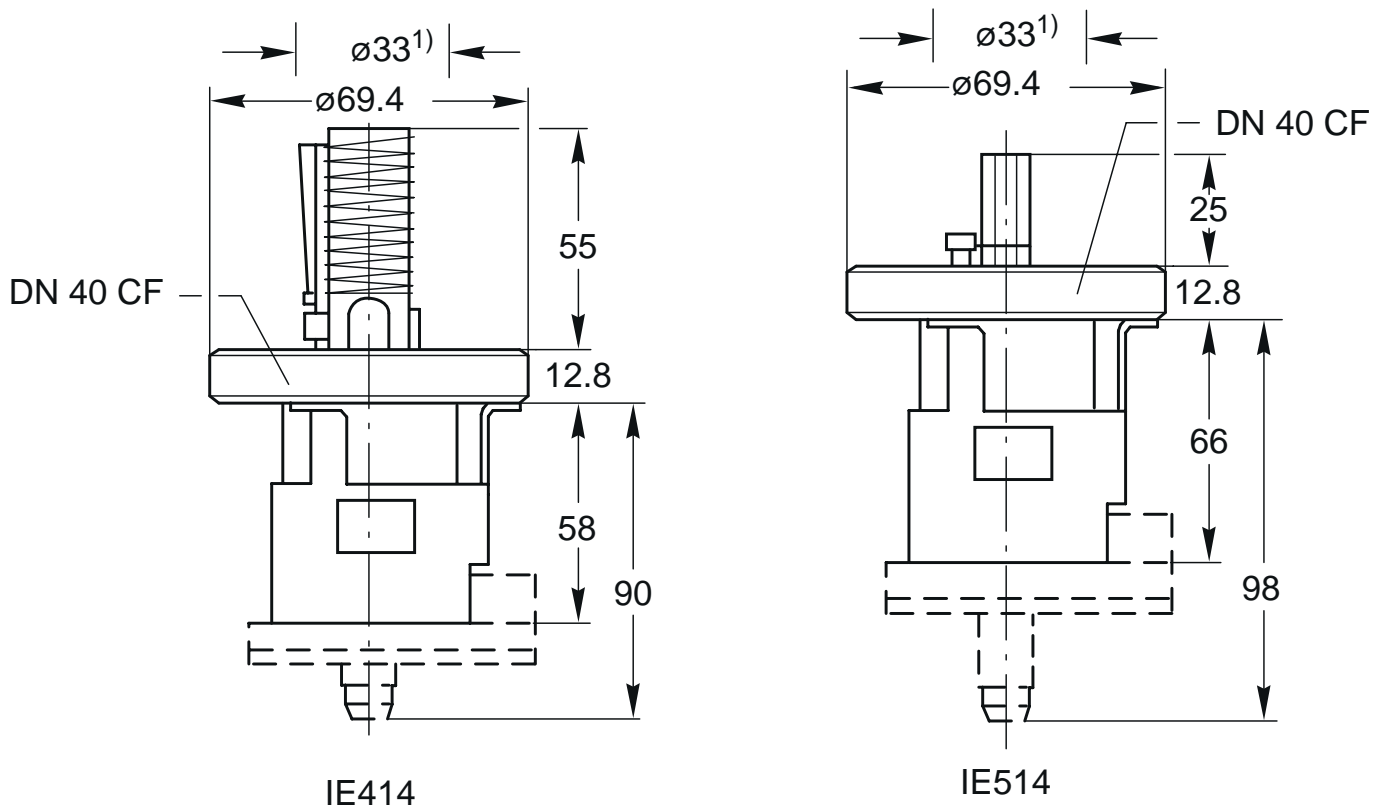

1) Diameter electrical feedthrough vacuum side.